

DLP Power & Motor Driver Data Register QFP-48

Address	Bit 7	6	5	4	3	2	1	Bit 0	
00h	0	0	0	0	1	1	1	1	0Fh
01h	1	0	0	0	0	0	0	0	80h
02h	0	0	0	0	0	0	0	0	00h
03h	0	0	0	0	0	0	0	0	00h
04h	0	0	0	0	0	0	0	0	00h
05h	0	0	0	0	0	0	0	0	00h
06h	0	0	0	0	0	0	0	0	00h
07h	0	0	0	0	0	0	0	1	01h
08h	0	0	0	0	0	0	0	0	00h
09h	0	0	0	0	0	0	0	0	00h
0Ah	0	0	1	1	0	0	0	0	30h

Address	Bit 7	6	5	4	3	2	1	Bit 0	
40h	0	0	0	1	0	0	0	0	1Fh 0Fh
41h									BEh BFh
42h	0	0	1	0	0	1	0	1	2Bh 25h
43h	0	0	1	0	1	0	1	0	2Ah
44h									
45h									
46h									09h
47h									
48h									
49h									00h
4Ah									

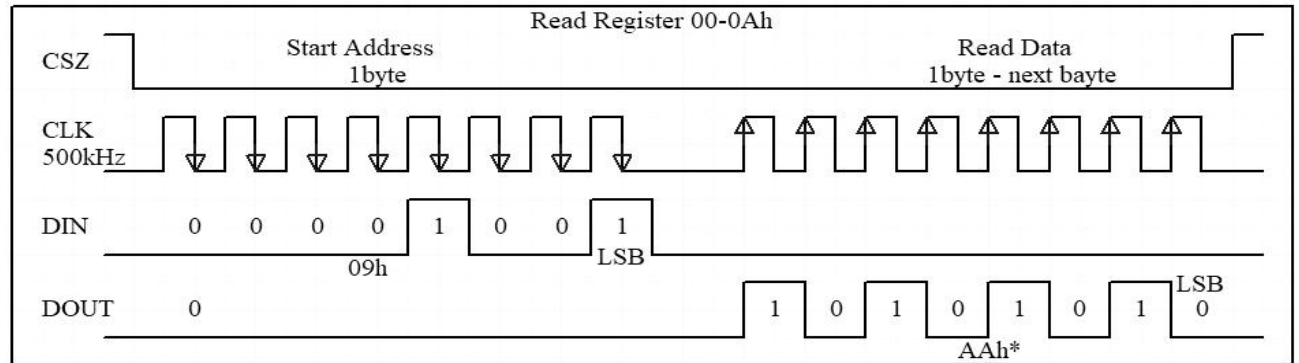
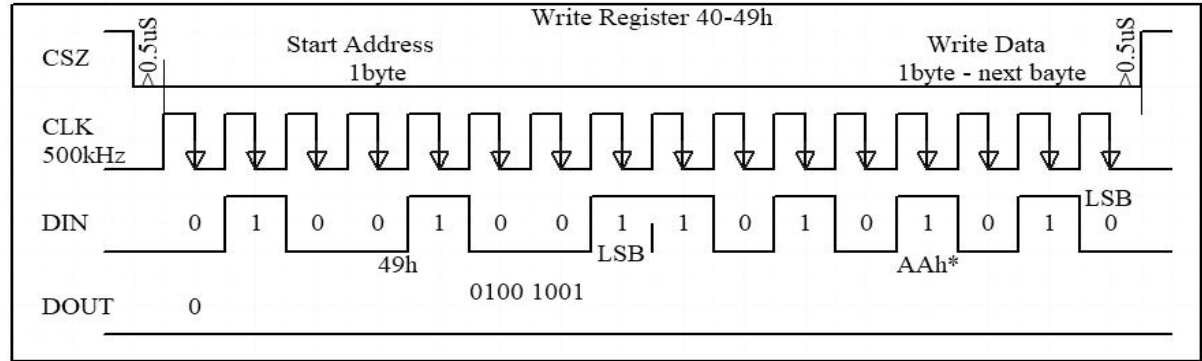

Pin6 OSC - 2MHz
Pin45,46 1K to +3V3

Register

40h Bit 4 1 - Motor On 0 - Motor Off

42h Bit 2:0 101 - OK

43h Bit 5 1 - OK

Bit 2 0 - OK

Bit 1 1 - CW 0 - CCW

